



IMPROX ISR

ImproX (ISR) IXP220 Registration Interface INSTALLATION MANUAL

SPECIFICATIONS

Working Environment	The ImproX ISR is designed to work in an indoor (dry) environment similar to IP20. The ImproX ISR is, therefore, NOT sealed against water.	
Scanner Operation	125 kHz.	
Input Voltage	5 V DC Supplied from the USB Port.	
Power Requirements	Current (mA)	Power (W)
Maximum Current Drawn from the USB Port	200	1.0
Third-party Port	5 V DC ± 0.1 V is supplied to power the single Reader connected to this Port. A maximum of 100 mA can be supplied from this Port.	
Installer Interfaces		
Registration Interface		
Power Indicator		
Power LED.....	Blue (steady) (externally visible).	
Diagnostic Indicators		
USB Tx LED.....	Red (flashing) (internally visible).	
USB Rx LED	Green (flashing) (internally visible).	
RS485 Tx LED	Red (flashing) (internally visible).	
RS485 Rx LED.....	Green (flashing) (internally visible).	

INSTALLATION INFORMATION

Accessories

Find the following when unpacking the Registration Interface:

- An ImproX (ISR) IXP220 Registration Interface housed in a Black, Aluminium extruded Cabinet. The Cabinet consists of a Top Cover, a Base and two End Plates (each End Plate is attached with three Thread Cutter Screws (M3 x 8 mm)).
- Four Brass Wood Screws (3.5 mm x 25 mm).
- Four Wall Plugs (7 mm).
- A 1.8 m (5.90 ft) standard USB Cable with a Type A to Type B Connector.
- An extra Fixed Address Label.

General

Remember the following when installing the Registration Interface:

FCC Compliance

For FCC compliance:

- Ensure the comms cable is routed through a separate grommet to the power cable.
- Ensure that you use a CE approved Power Supply Unit.

Communications Distance

- The USB communications distance between the Host PC and the Registration Interface MUST NOT exceed 5 m (16.40 ft).
- DO NOT cut and join the supplied USB Cable. If extension of the USB Cable is required, source a new longer length USB Cable.

Mounting the Cabinet

CAUTION: Make certain that you mount the ImproX ISR on a vibration-free surface.

Select the mounting position of the ImproX ISR, considering accessibility, routing of wires and visibility of the externally visible LED.

Secure the Cabinet to the mounting surface, using four suitable screws and wall plugs (supplied), nuts and bolts or rivets.

Blank Space

DIP-switch Settings

The format selection for each type of device that can be connected to the Third-party Port is made by setting the internal DIP-switches as indicated in Table 1.

NOTE: Terminals 'A' and 'B' in Table 1 are on the Third-party Port Terminal Block.



DIP-switch Position	Format	Connections
0  DIP-switch 0 shows all the switches in the OFF position	No peripheral Reader	N/A
1  DIP-switch 1 shows switches 2, 3 and 4 in the OFF position	Mifare Remote	Rx to terminal 'A' Tx to terminal 'B'
2 	RF Receiver	Data Line to terminal 'B'
3 	Magstripe ABA Track 2	Data Line to terminal 'A' Clock Line to terminal 'B'
4 	Barcode Code-39 with Checksum	Data Line to terminal 'B'
5 	Barcode Code-39 without Checksum	Data Line to terminal 'B'
6 	Wiegand 26/37/40 and 44	0 Data Line to terminal 'B' 1 Data Line to terminal 'A'
7 	Wiegand Open Format	0 Data Line to terminal 'B' 1 Data Line to terminal 'A'

Table 1: DIP-switch Settings

NOTE: Once the DIP-switch setting is modified reset the ImproX ISR to acknowledge the new settings.

Blank Space

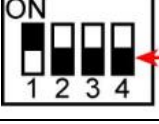
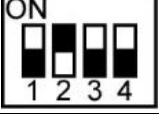
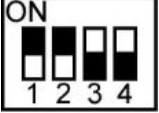
CONNECTING THE REGISTRATION INTERFACE

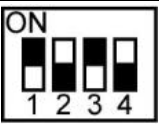
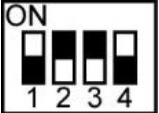
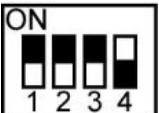
Figure 1 shows a detailed connection diagram for the ImproX ISR.

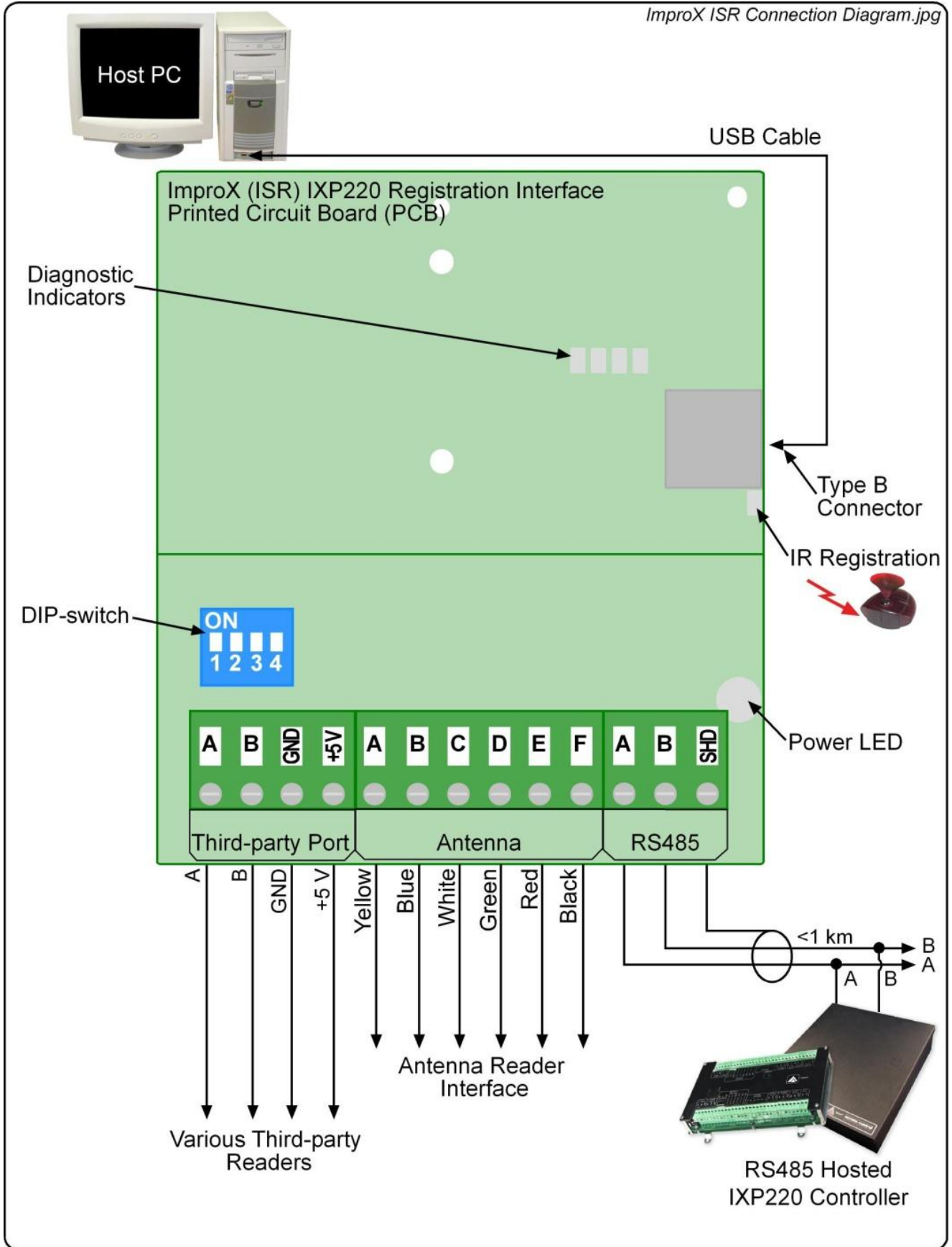

Figure 1: Typical ImproX ISR Electrical Connections

Power-on Self-test

The Power-on Self-test tests the RAM and Flash Checksums.

Testing the Connection

When you connect the Registration Interface to the PC for the first time, the PC will prompt you to install the necessary Drivers, once installed, the Power LED will illuminate Blue (steady).

This confirms the Registration Interfaces connection is correct and working.

Further connections on the same PC will not call for reloading the Drivers.

Fixed Address Label

Keep the Fixed Address Label in a safe place, as you may need the Label at a later date if you wish to upgrade your Software.

GUARANTEE OR WARRANTY

This product conforms to our Guarantee or Warranty details placed on our Web Site, to read further please go to www.impro.net.

USER NOTES

USER NOTES

USER NOTES



This manual is applicable to the ImproX (ISR) IXP220 Registration Interface,
ISR901-1-0-GB-00.

(The last two digits of the Impro stock code indicate the issue status of the product).

ISR305-0-0-GB-06	Issue 07	Nov 2009	ImproX ISR\English Manuals\LATEST ISSUE\ XISR901-in-sm-en-07.docx
------------------	----------	-------------	--